

MODEL 43

INSIDE DIAMETER PIPE WELD HEAD

AMI
ARC MACHINES, INC.®

The widest range of orbital welding equipment in the world



The Model 43 is a rugged inside diameter welding head for ID cladding or welding of pipe joints. It is designed for remote controlled repair welds of nuclear valves and has been used extensively in nuclear components assembly plants as well as fossil-fuel power generation, chemical, and vessel manufacturing.

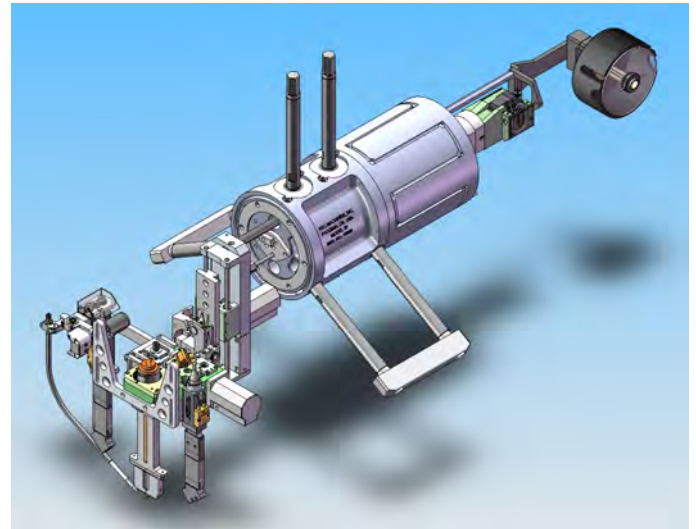

The Model 43 can be equipped with a wide variety of GTAW torches and wire feed options including a remote controlled torch equipped with an AMI advanced arc viewing video system.

The main housing of the Model 43 is water cooled allowing the weld head to be used for applications which require high preheated conditions.

QUICK SPECS

AVC Stroke

1.75" (44 mm) or
3.00" (76 mm) optional

Torch Oscillation

1.00" (25 mm) maximum
1.5" (38 mm) optional

Wire Feed Speed

1.0 - 200 IPM
(25 - 5000 mm/min.)

Travel Speeds

0.005 - 0.5 RPM

Tungsten Size

3/32" or 1/8"
(2,4 or 3,2 mm Ø)

Filler Wire

0.030" or 0.035"
(0,8 or 0,9 mm Ø)

Wire Spool

2 lbs. or 4" standard spool
(1 kg or 100 mm Ø spool)

Torch Cross-Seam Steering Range

2.00" (50 mm) or
3.00" (76 mm) optional

Weight Including Remote Vision

36 lbs. (less cables)
(16 kg)

ID Range

6.75" - 24.0"
(171 — 610 mm)

Torch

Water-cooled, 250 A
100% Duty Cycle

Remote Torch Tilt

+/- 15°

www.arcmachines.com

sales@arcmachines.com

MODEL 43 INSIDE DIAMETER PIPE WELD HEAD

STANDARD FEATURES

1. Servo-controlled rotation
2. Servo-controlled AVC
3. Servo-controlled synchronized wire feed
4. Servo-controlled torch oscillation and dwell
5. Electronically controlled torch steering
6. Water-cooled body for use in pre-heated pipes
7. Remote-controlled, motorized wire nozzle adjustment
8. Remote-controlled, motorized torch tilt

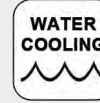

OPTIONAL HARDWARE

- Direct-view cameras, to monitor leading and trailing edges of weld puddle
- Dual wire feed to weld in either direction
- Large selection of torches for welding inside diameters
- Remote vision torch with direct-view video cameras and remote torch tilt/remote wire manipulation

AREAS OF USE

- Narrow gap ID welding
- Remote controlled ID cladding, welding and repair
- Nuclear valve repairs
- Vessel manufacturing



Compatible with:

- Model 415 programmable multi-function Power Supply
- Model 501 Hot Wire Power Supply

*Leaders & Innovators in
Automated Orbital Welding*

*For further information please visit our website
or contact us at 1-818-896-9556*



AMI
ARC MACHINES, INC.®

www.arcmachines.com

sales@arcmachines.com

HEADQUARTERS

Arc Machines, Inc.

10500 Orbital Way
Pacoima, CA 91331 U.S.A.
Tel: +1 / 818 / 896 / 9556
Fax: +1 / 818 / 890 / 3724
sales@arcmachines.com

EUROPEAN BRANCH OFFICE

Arc Machines, Inc.

Chemin du Lavasson 2, CH-1196
Gland, Switzerland
Tel: +41 / 22 / 995 / 0051
Fax: +41 / 22 / 995 / 0059
sales@arcmachines.ch

GERMAN OFFICE

Arc Machines GmbH

Markelsbach 2
D-53804 Much, Germany
Tel: +49 / 2245 / 91680
Fax: +49 / 2245 / 916868
sales@arcmachines.de

UK OFFICE

Arc Machines UK Limited

Unit 2 Lamport Court
Heartlands Business Park
Daventry, NN11 8UF, UK
Tel: +44 / 1327 / 312787
Fax: +44 / 1327 / 315034
sales@arcmachines.co.uk